

SNELSTARTGIDS

EN QR CODES VOOR APPS EN PC SOFTWARE

GUIDE DE DÉMARRAGE RAPIDE

ET CODE QR POUR LES APPLICATIONS ET LES LOGICIELS PC

Kurzanleitung

UND QR-CODE FÜR APPS UND PC-SOFTWARE

Continental M17

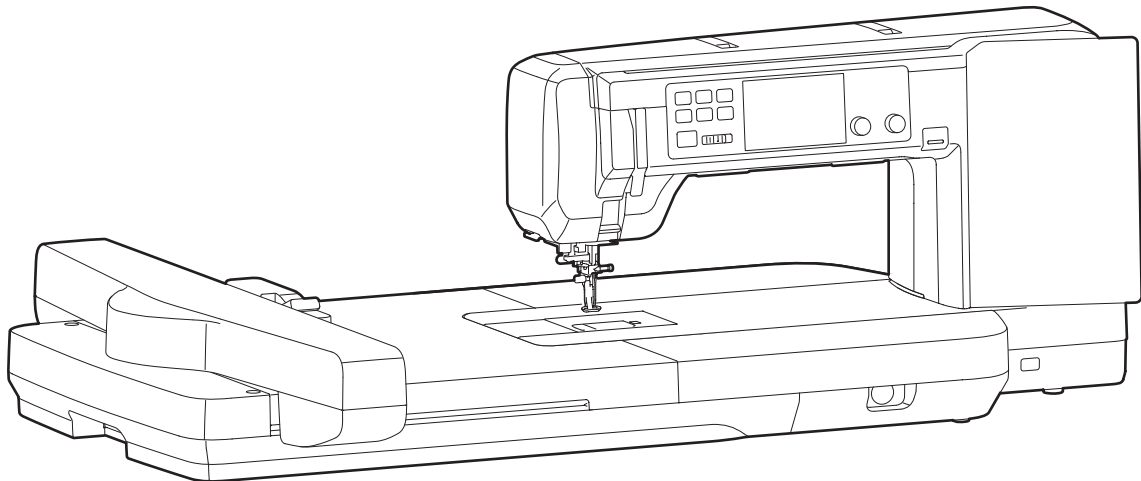

INHOUDSOPGAVE

De spoel opwinden	2
De spoel plaatsen	3
De machine inrijgen	4 - 5
Borduren voorbereiden	6
De naaldplaat verwisselen	7
De borduureenheid bevestigen	8
De stof in de borduurring plaatsen	9
Verzorging en onderhoud	10 - 11
iOS en Android Apps en Windows software	12 - 13

TABLE DES MATIÈRES

Bobinage d'une canette de fil	2
Insertion de la canette	3
Enfilage de la machine	4 - 5
Préparation de la broderie	6
Remplacement de la plaque aiguille	7
Fixation du module de broderie	8
Mise en place du tissu dans le cadre à broder	9
Entretien de votre machine	10 - 11
Applications iOS et Android et logiciels Windows	12 - 13

INHALTSVERZEICHNIS

Aufspulen	2
Spule einlegen	3
Maschine einfädeln	4 - 5
Vorbereitung zum Sticken	6
Stichplatte austauschen	7
Anbringen der Stickeinheit	8
Stoff in einen Stickrahmen einspannen	9
Pflege und wartung	10 - 11
iOS , Android Apps und Windows Software	12 - 13

Download site voor handleidingen
Site de téléchargement des modes d'emploi
Downloadseite und QR Code für die
Bedienungsanleitung



URL: <https://www7.janome.co.jp/global/product/machineupdates/>

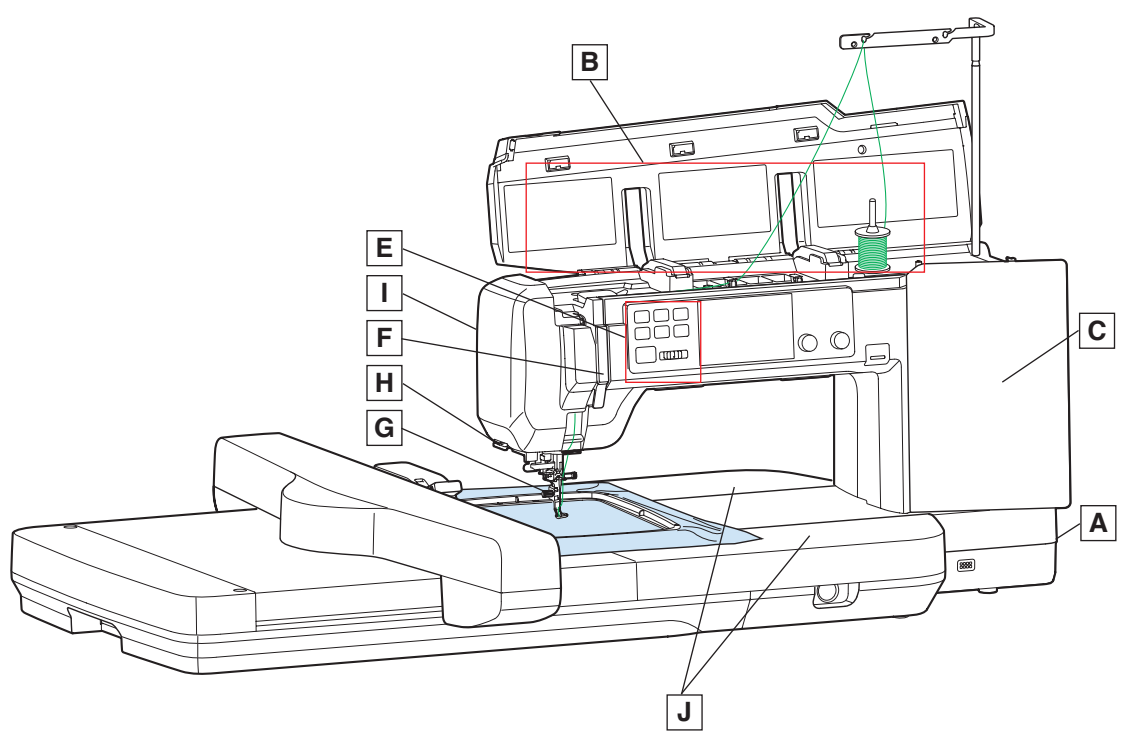
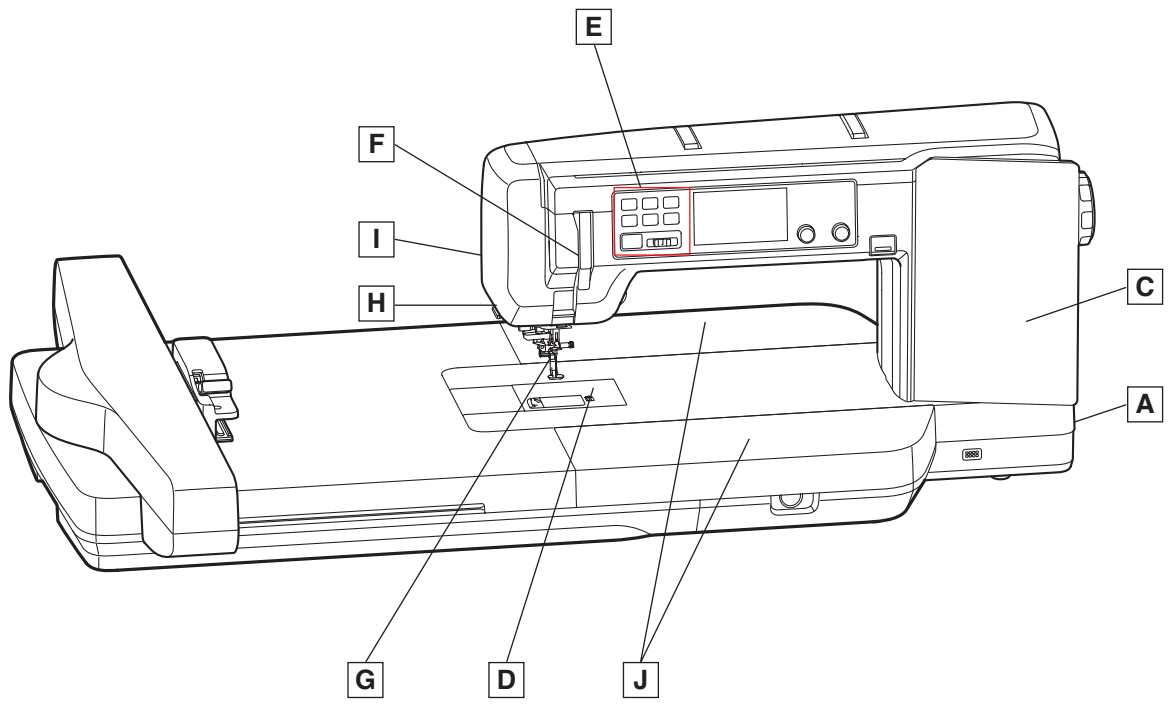

De spoel opwinden / Bobinage d'une canette de fil / Aufspulen

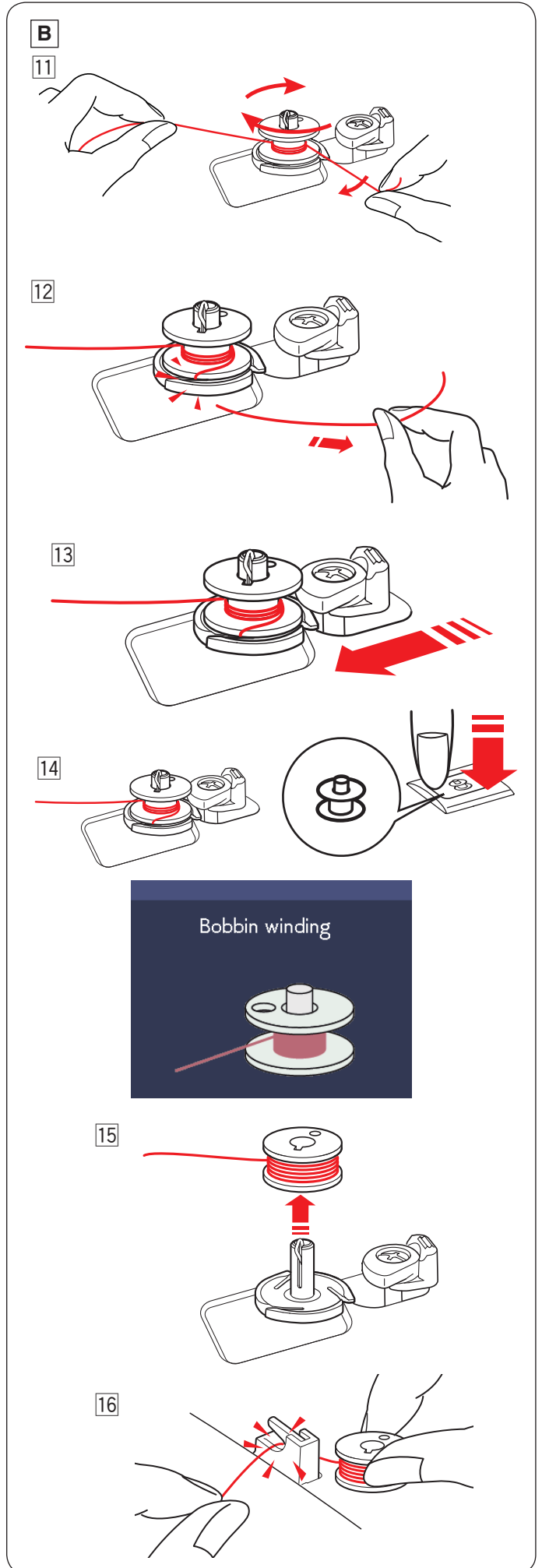
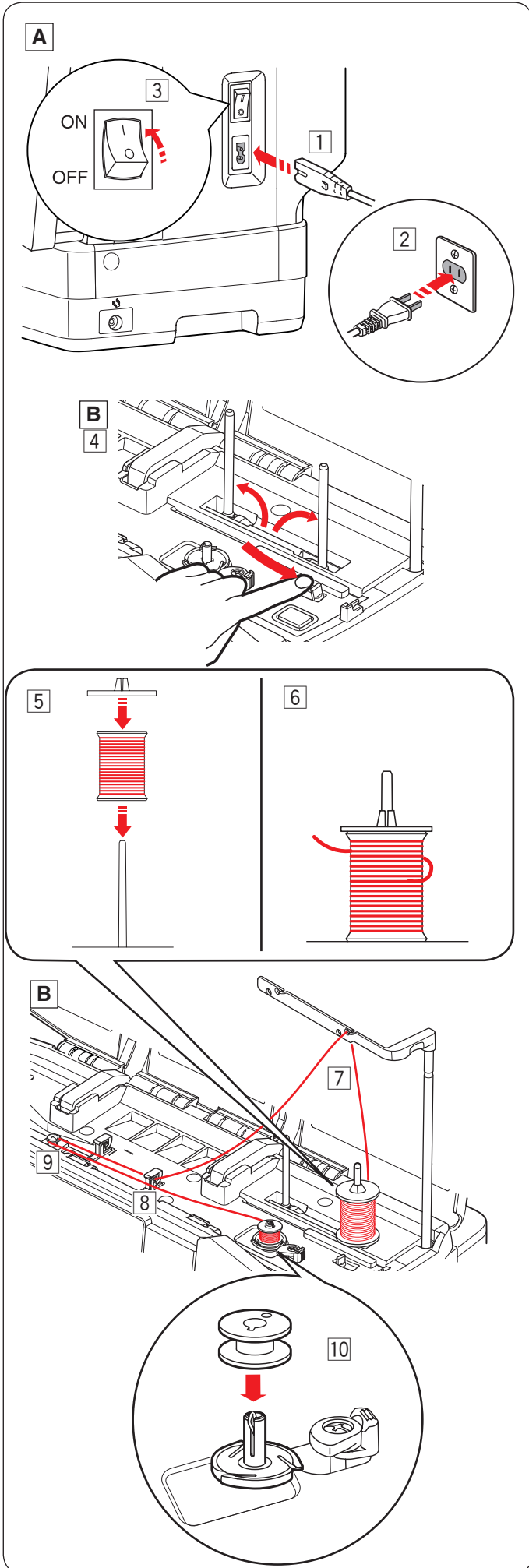

De spoel plaatsen / Insertion de la canette / Spule einlegen

C

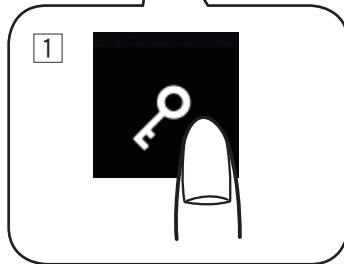
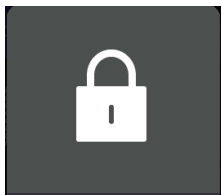

D

2

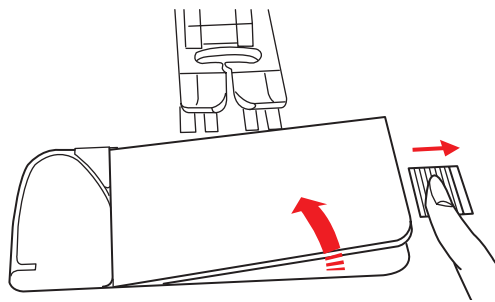

3

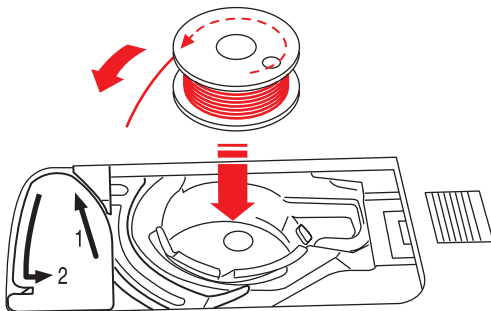

4

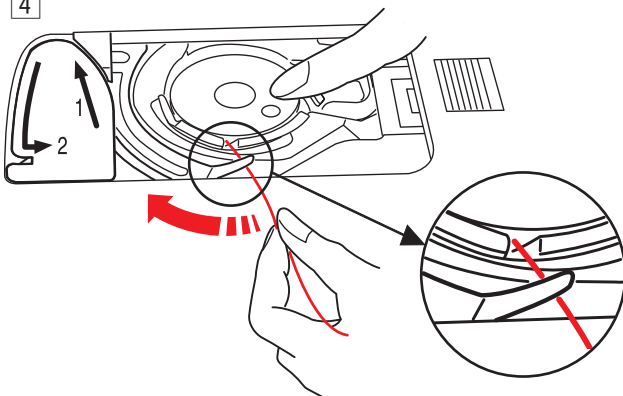

D

5

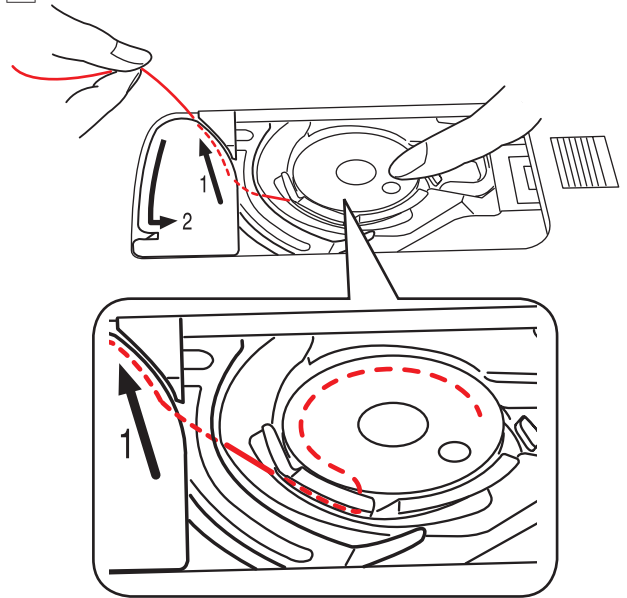

6

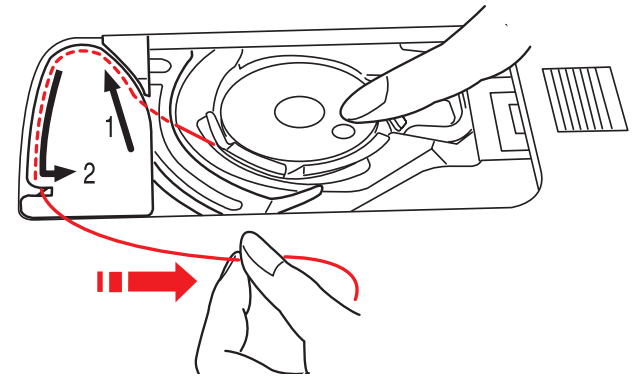

7

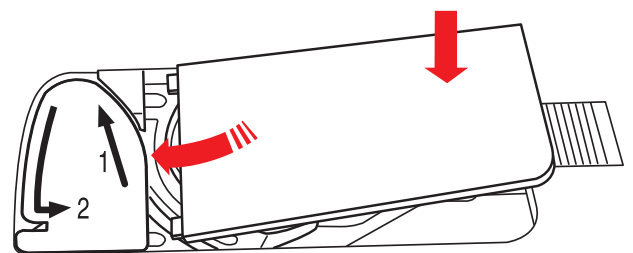

De machine inrijgen / Enfilage de la machine / Maschine einfädeln

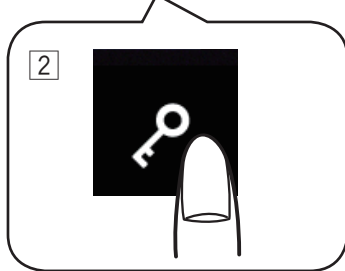
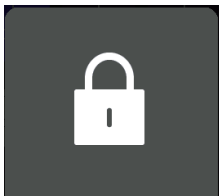
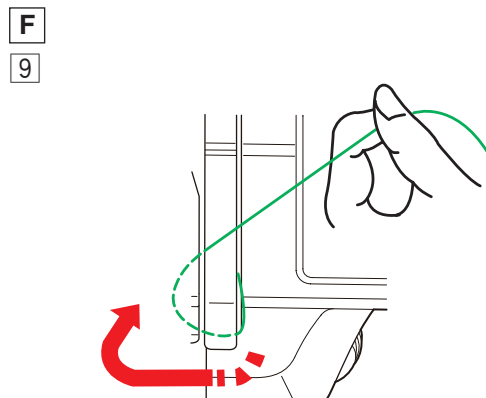
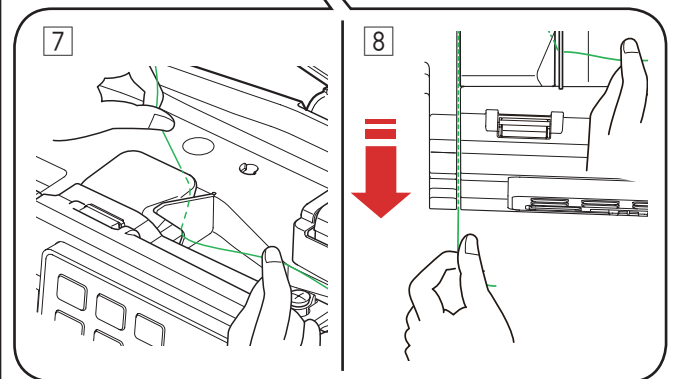
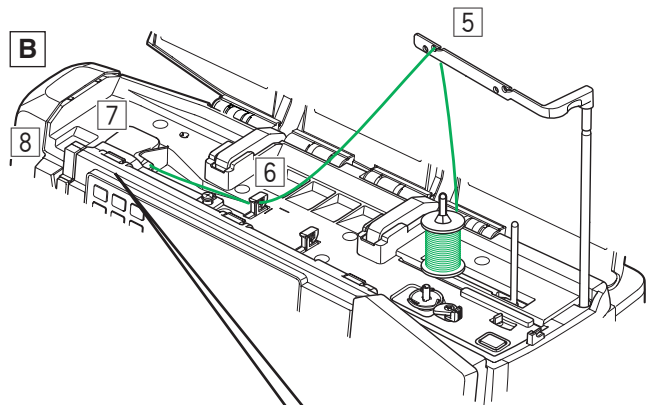
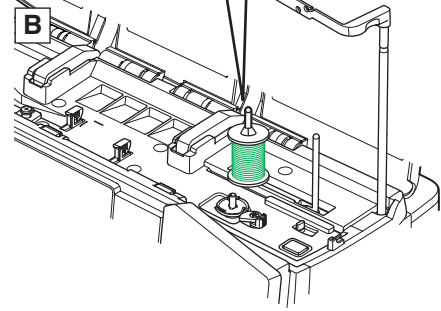
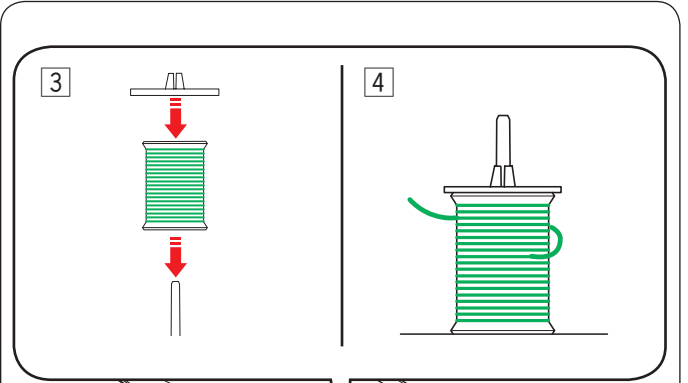
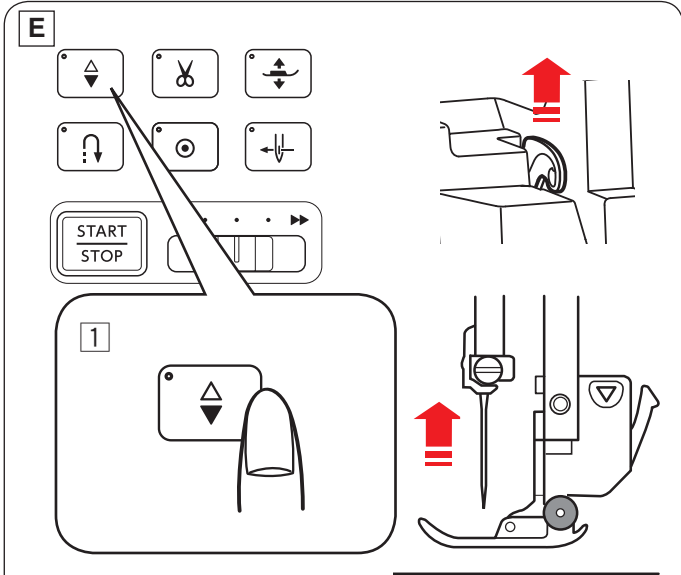

De machine inrijgen / Enfilage de la machine / Maschine einfädeln

F
10

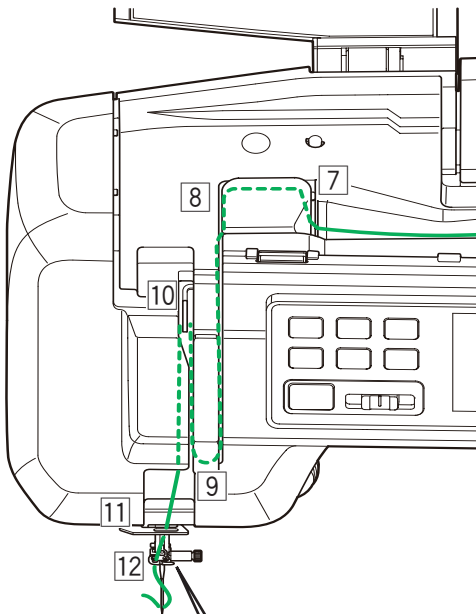
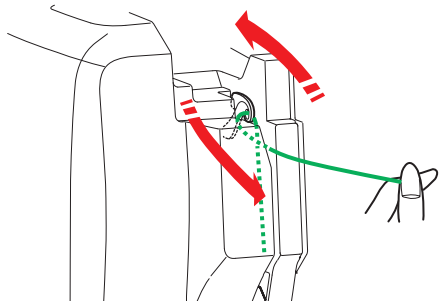

G

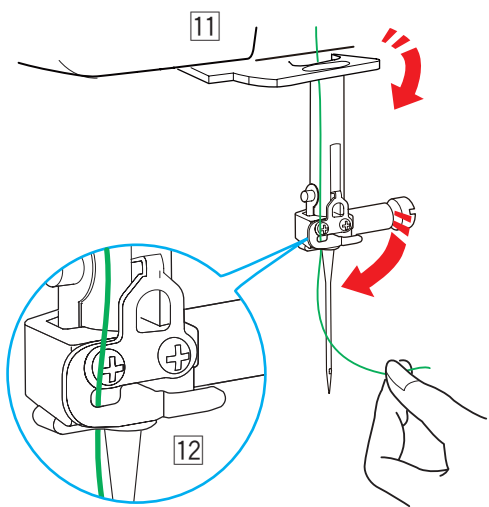

G
13

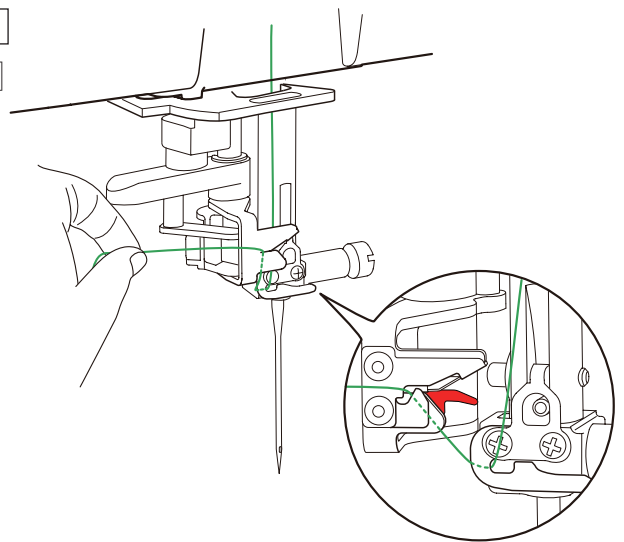

H
14

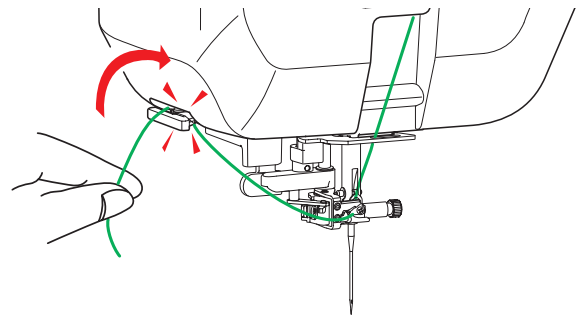

E
15

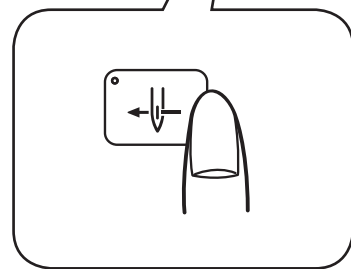
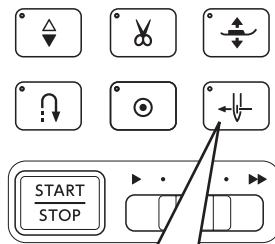

G
16

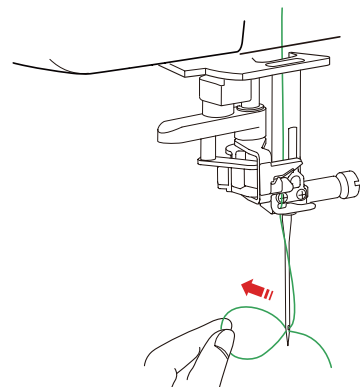

Borduren voorbereiden / Préparation de la broderie
/ Vorbereitung zum Sticken

C

1

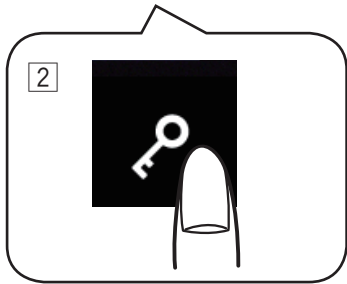
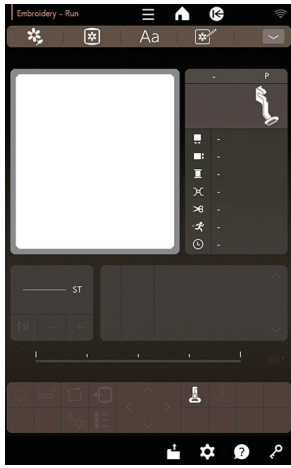

D

3

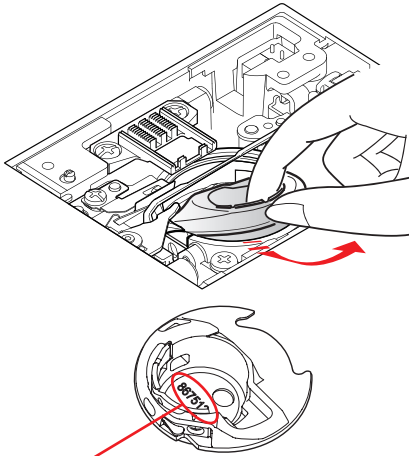

No. 867513208 (Borduren / Broderie / Stickerei)

4

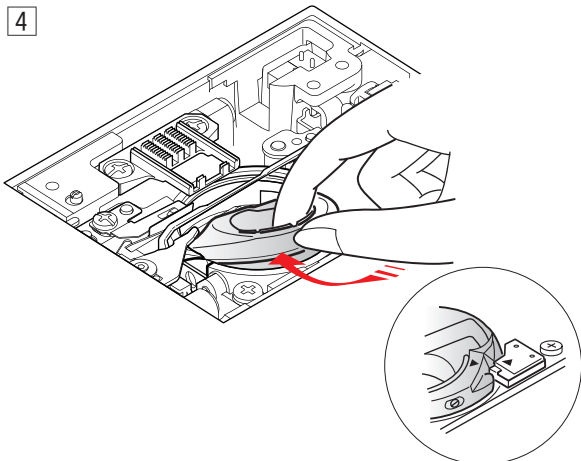

I

5

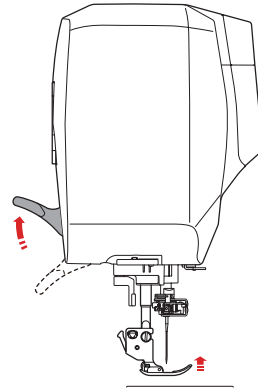

G

6

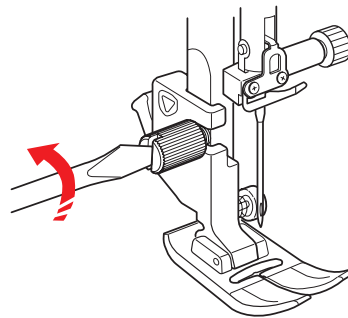

7

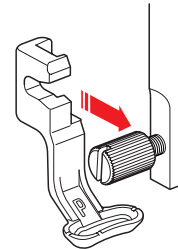

8

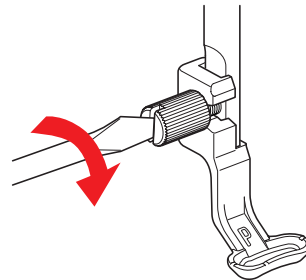

De naaldplaat verwisselen / Remplacement de la plaque aiguille
/ Stichplatte austauschen

C

1

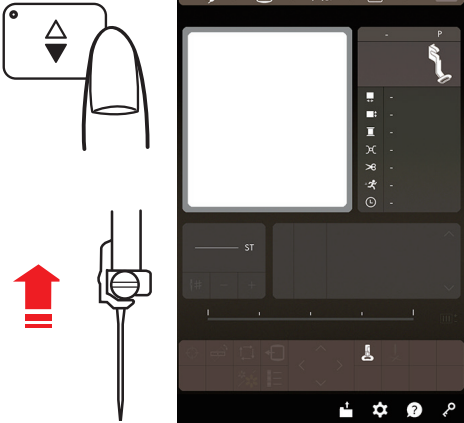

3

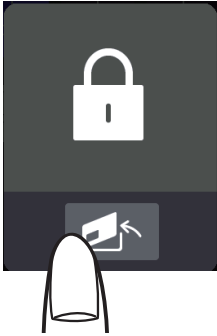

2

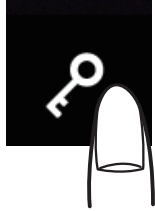

D

4

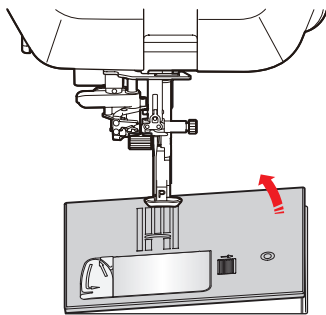

D

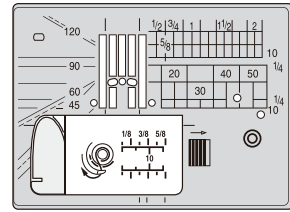

No. 867802001 (Borduren / Broderie /
Stickerei)

5

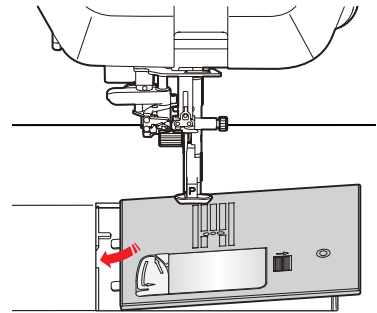

De borduureenheid bevestigen / Fixation du module de broderie
/ Anbringen der Stickeinheit

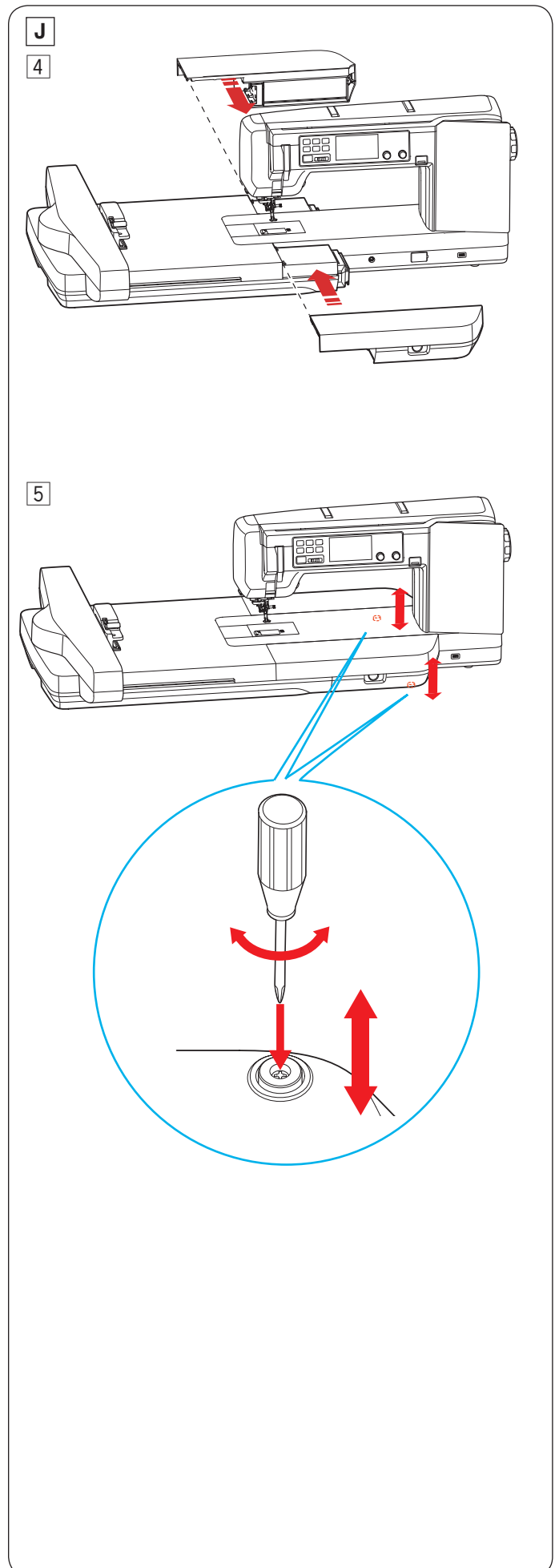
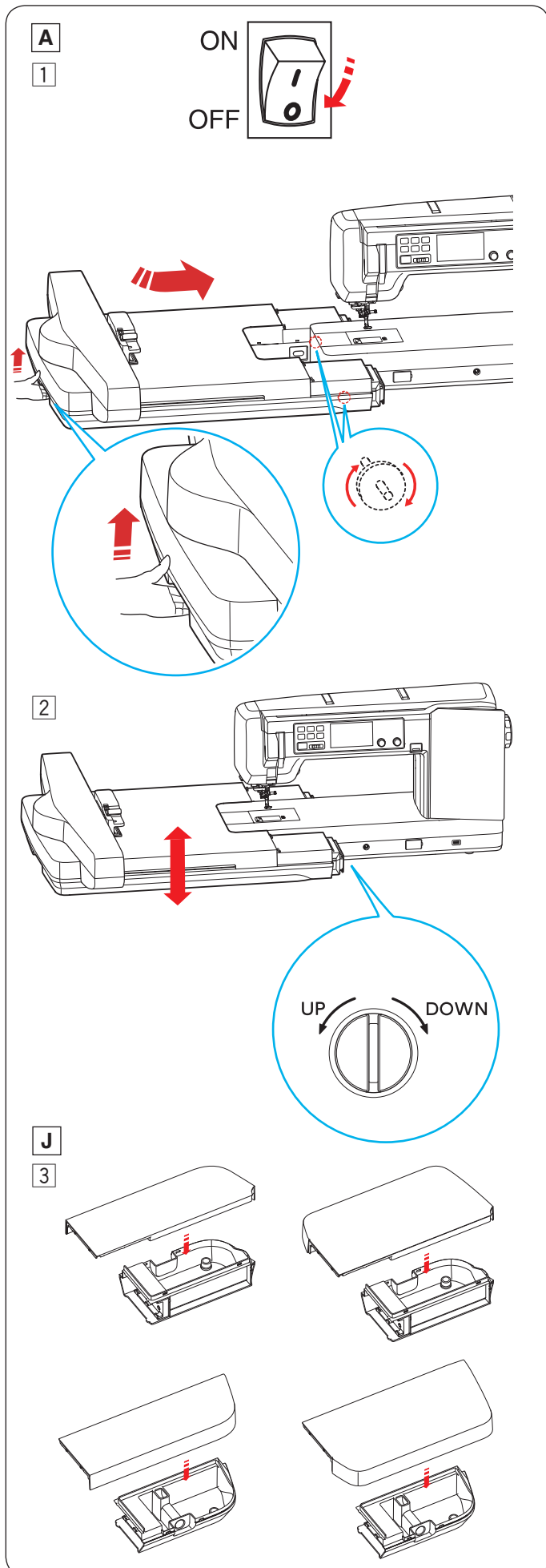

De stof in de borduurring plaatsen / Mise en place du tissu dans le cadre à broder
/ Stoff in einen Stickrahmen einspannen

1

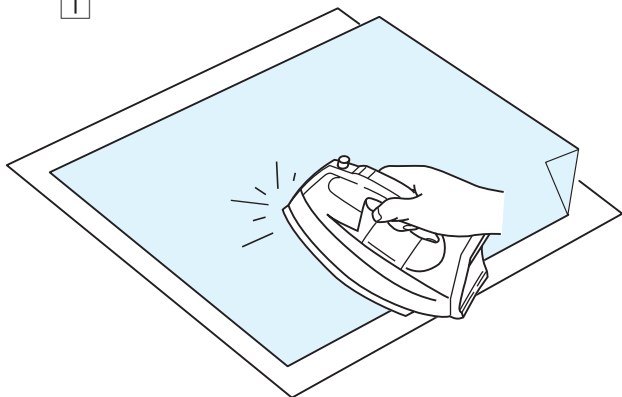

2

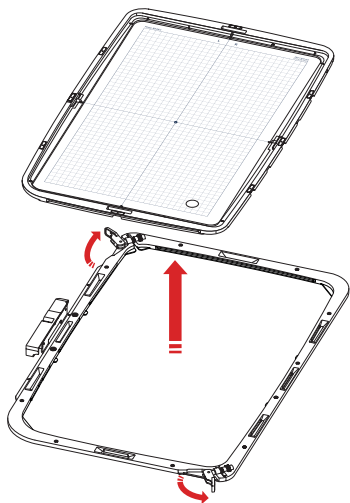

3

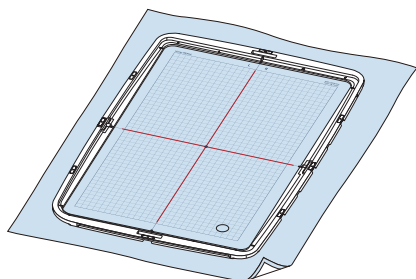

4

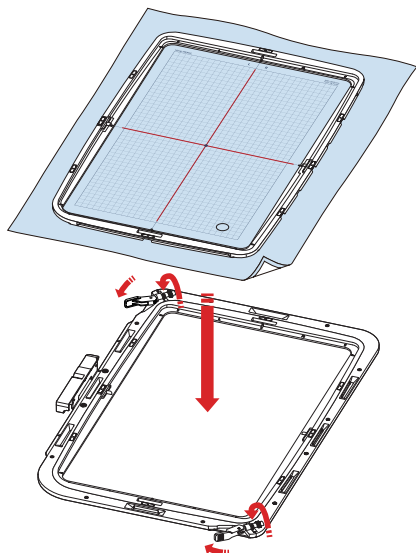

5

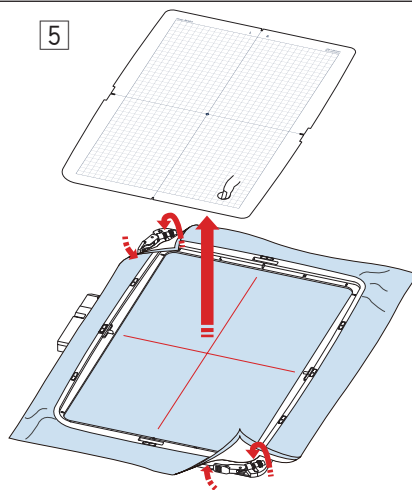

6

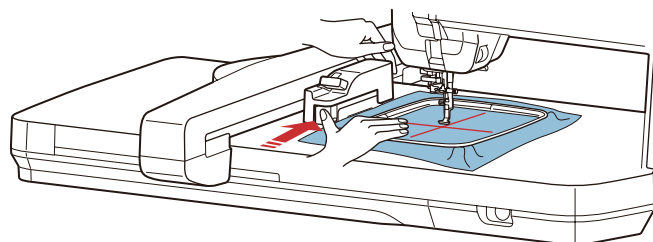
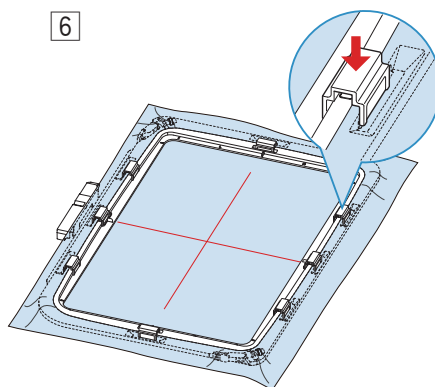

Verzorging en onderhoud / Entretien de votre machine / Pflege und wartung

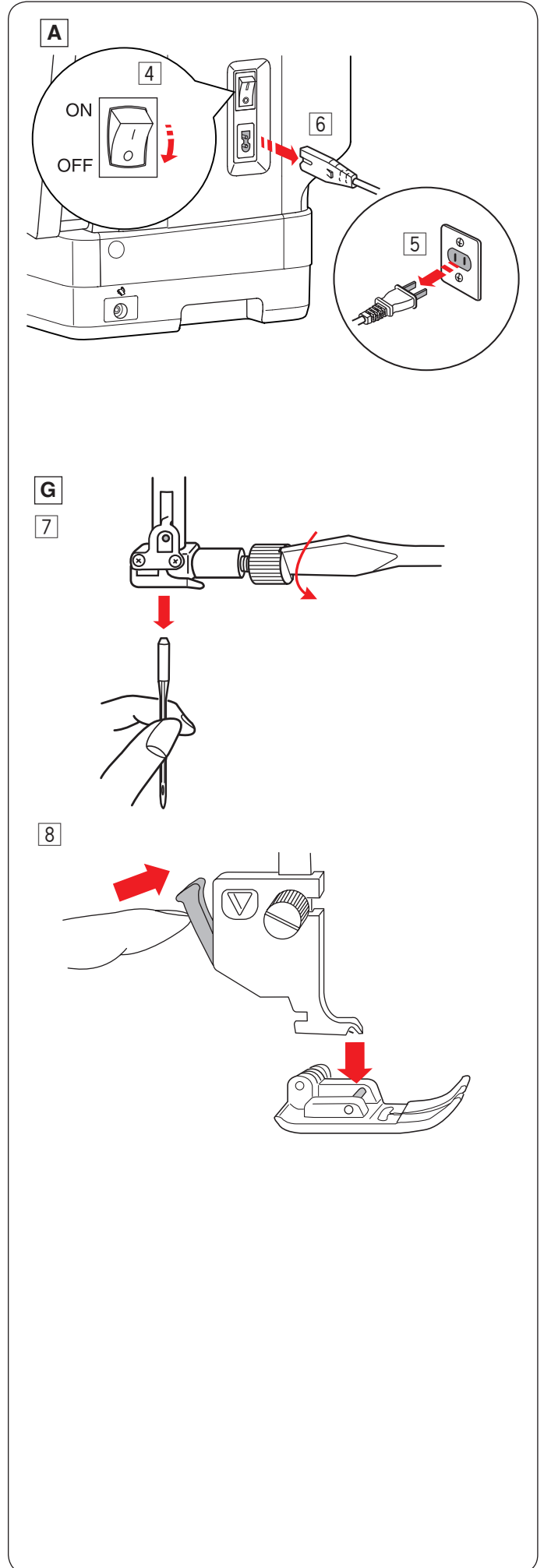
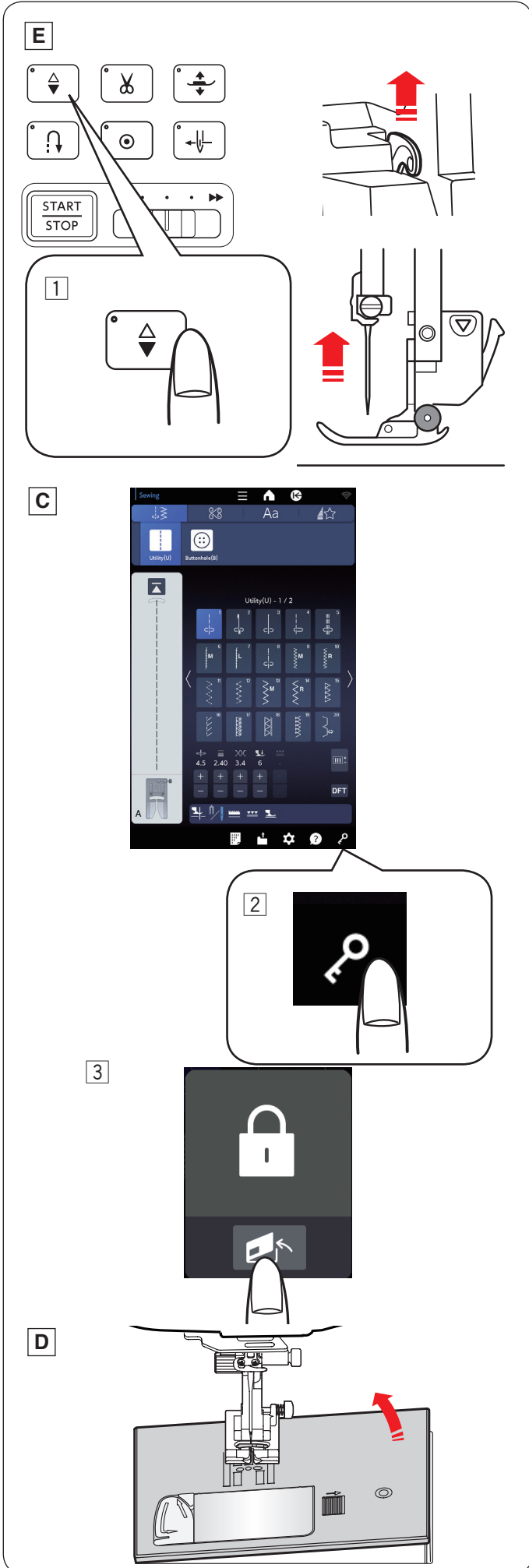

D

9

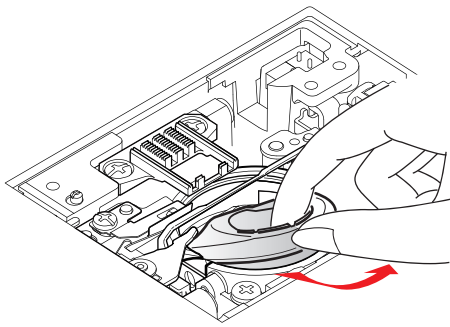

10

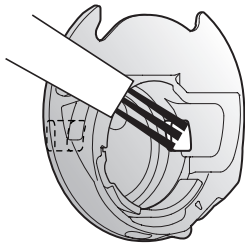

11

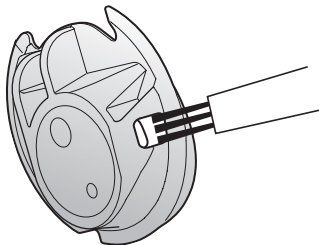

12

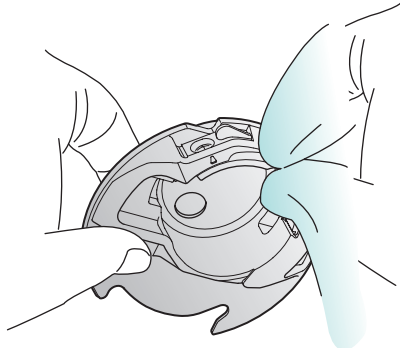

13

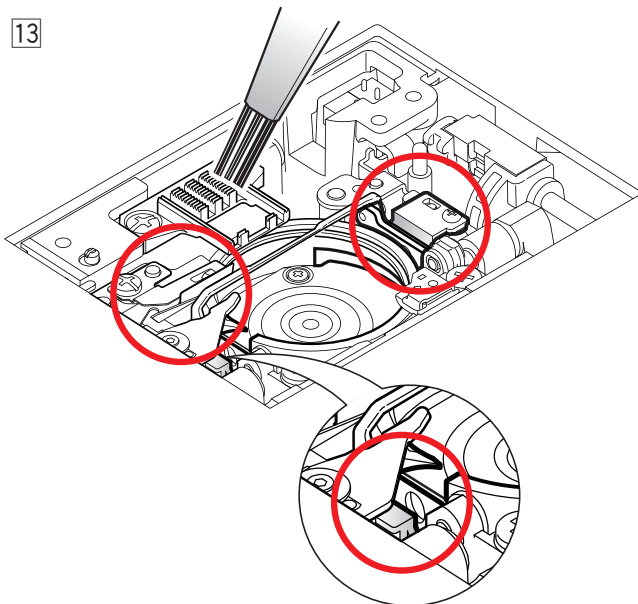

D

14

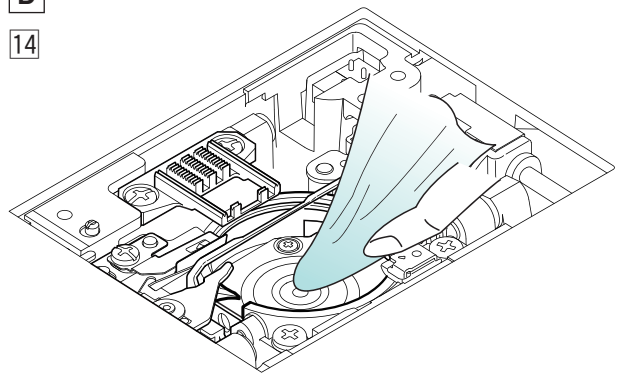

15

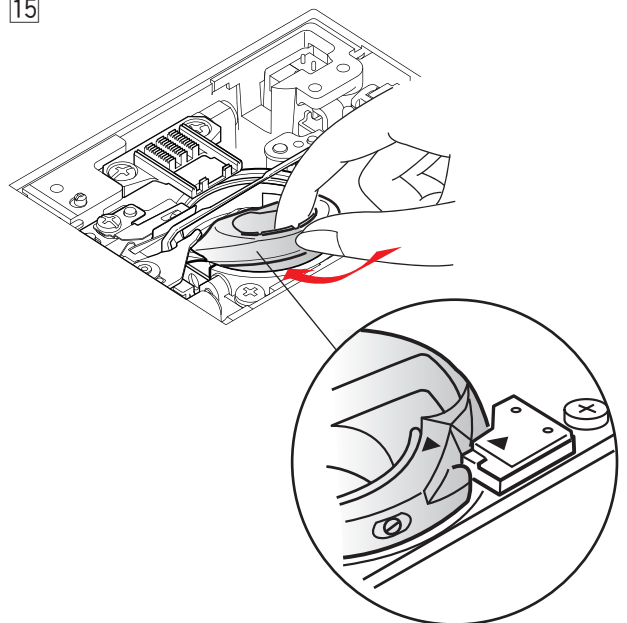

iOS en Android Apps en Windows software / Applications iOS et Android et logiciels Windows / iOS und Android Apps und Windows Software

Gebruik de QR codes om deze handige software te downloaden.

Utilisez les codes QR pour accéder à ces outils utiles.

Verwenden Sie die QR-Codes, um Zugriff auf diese nützlichen Tools zu erhalten.



AcuAssist (iOS, Android)

Naaimachine gebruikersgids en tips App.

Guide d'utilisation et application de conseils de la machine à coudre.

App für die Nähmaschinen-Bedienungsanleitung und Tipps zur Maschine.

URL: <https://www7.janome.co.jp/global/softupdate/acuassist/>



AcuSetter (iOS, Android)

App voor het accuraat plaatsen van borduurwerk.

Application pour un placement précis de la broderie.

App zur genauen Platzierung von Stickereien.

URL: <https://www7.janome.co.jp/global/softupdate/acusetter/>



AcuSketch (iOS, Android)

App voor het maken van borduur bestanden van tekneingen/schetsen.

Application permettant de créer des données de broderie à partir de dessins / croquis.

App zur Erstellung von Stickdaten aus Zeichnungen / Skizzen.

URL: <https://www7.janome.co.jp/global/softupdate/acusketch/>



ScreenSaverTool (iOS, Android)

App voor het instellen van screensaver afbeeldingen op de naaimachine.

Application permettant de définir des images d'économiseur d'écran sur votre machine à coudre.

App zum Erstellen von eigenen Bildschirmschonerbildern auf Ihrer Nähmaschine.

URL: <https://www7.janome.co.jp/global/softupdate/screensavertool/>



Embroidery-Link (iOS, Android)

App voor borduurmotieven bewerken en het checken van de borduurvoortgang.

Application permettant d'éditer des modèles de broderie et de suivre la progression de la broderie.

App zur Bearbeitung von Stickmustern und Überwachung des Stickprozesses.

URL: <https://www7.janome.co.jp/global/softupdate/embroidery-link/>



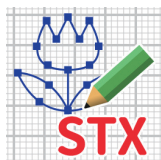

PC software (Windows)

- **StitchComposer**
- **ScreenSaverTool**
- **QuiltBlockAdviser**
- **AcuFilTool**



Software voor het maken van borduur bestanden, het instellen van screensavers en quilt patronen schikken.

Logiciel permettant de créer des données de points, de définir des économiseurs d'écran sur votre machine à coudre et d'organiser des motifs de matelassage.



Software zum Erstellen von Zierstichen, Individualisieren des Bildschirmschoners Ihrer Nähmaschine und Gestalten von Quiltmustern.

URL: <https://www7.janome.co.jp/global/product/softwareapps/pc-software-for-continental-m17/>



(Nederlands)

- QR code reader (scanner) applicatie kan worden gedownload van de App store of market.
- Het kan enige momenten duren voordat de site reageert bij het scannen van een QR code.
- Uw internetprovider kan uw gebruikelijke kosten in rekening brengen.
- Design of App iconen kunnen zonder voorafgaande kennisgeving aangepast worden.
- iOS is de naam van het besturingssysteem ontwikkeld door Apple Inc.
- iOS is een handelsmerk van Cisco Systems Inc. geregistreerd in de V.S. en andere landen waar dit onder licentie in gebruik is.
- Android en Google Play zijn handelsmerken van Google LLC.
- QR Code is een geregistreerd handelsmerk van Denso Wave Inc.
- iTunes Store en Apple Store zijn handelsmerken van Apple Inc. geregistreerd in de V.S. en andere landen.

(Français)

- L'application de lecteur de code QR (scanner) peut être téléchargée à partir de l'App Store ou sur le marché.
- Cela peut prendre un certain temps pour recevoir une réponse du site lors du balayage d'un code QR.
- Des frais de données standard de votre fournisseur d'accès Internet peuvent s'appliquer.
- La conception d'icônes d'application est sujette à modification sans préavis.
- iOS est le nom du logiciel du système d'exploitation créé par Apple Inc.
- iOS est une marque commerciale de Cisco Systems Inc. enregistrée aux États-Unis et dans d'autres pays et est utilisée sous licence.
- Android et Google Play sont des marques commerciales de Google LLC.
- QR Code est une marque déposée de Denso Wave Inc.
- iTunes Store et Apple Store sont des marques commerciales d'Apple Inc. enregistrées aux États-Unis et dans d'autres pays.

(Deutsch)

- Die Anwendung für den QR-Codeleser (Scanner) kann aus dem App Store oder vom Marktplatz heruntergeladen werden.
- Es kann einige Zeit dauern, bis Sie beim Scannen eines QR-Codes eine Antwort von der Website erhalten.
- Es können Standardgebühren für Datenübertragung bei Ihrem Internetanbieter anfallen.
- Das Design der App-Symbole kann ohne Vorankündigung geändert werden.
- iOS ist der Name der Betriebssystemsoftware, die von Apple Inc. erstellt wurde.
- iOS ist eine in den USA und anderen Ländern eingetragene Marke von Cisco Systems Inc. und wird unter Lizenz verwendet.
- Android und Google Play sind Marken von Google LLC.
- QR Code ist eine eingetragene Marke von Denso Wave Inc.
- iTunes Store und Apple Store sind Marken von Apple Inc., die in den USA und anderen Ländern eingetragen sind.

